

DY 系列三次元振动筛分机

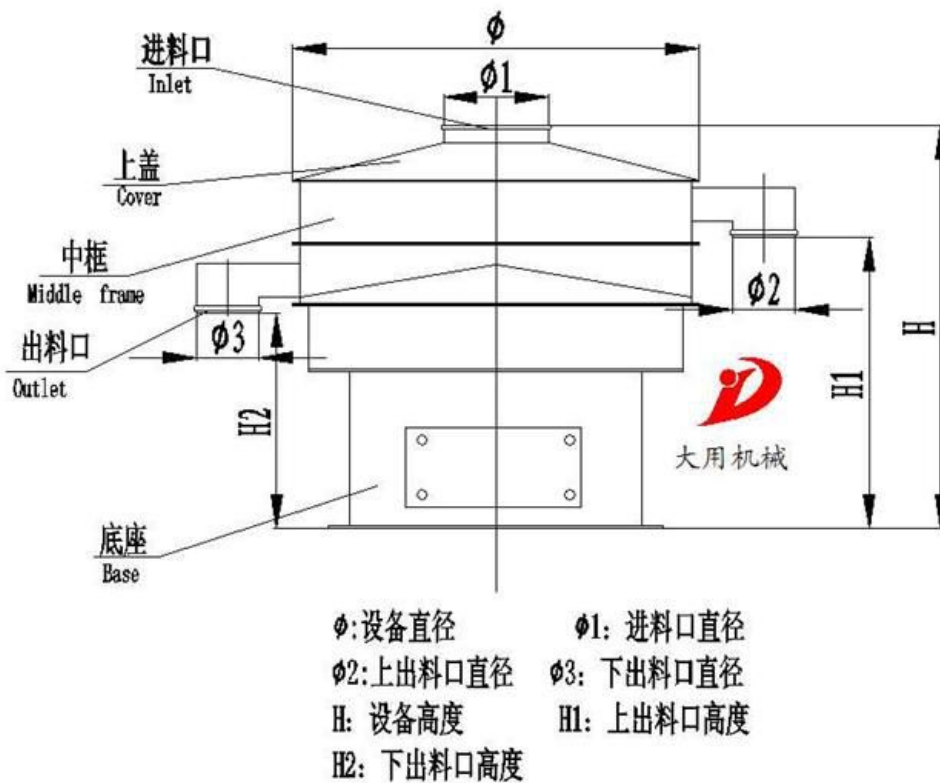

结构图：



工作原理：

Working principle:

on the top and bottom of the vertical vibration motor through installing eccentric

hammer, make motor rotation movement into level, vertical and inclined three dimensional movement. And then transfer the movement to the screen surface. Change the phase angle of hammer on the top and bottom of the vertical vibration motor, as a result changing the movement direction of the material.

通过在立式振动电机上下安装的偏心重锤,使电机的旋转运动转变为水平,垂直,倾斜的三次元运动。然后再把这个运动传递给网面。改变电机上下重锤的相位角可以改变物料的运动方向。

工作模拟图:

Work simulation diagram:

Three dimensional vibrating screen is mainly divided into three types:

Grade separation, Separation of impurities, Solid-liquid separation.
三次元振动筛主要分为三种类型: 等级分离, 杂质分离和固液分离。



特点:

Features:

1. 效率高、设计精巧、任何粉类、粘液均可筛分。

1. High efficiency, refined design, suit for any powders and mucilage screening.

2. 换网容易、操作简单、清洗方便。

Easy to replace the screen, simple operation, easy to clean.

3. 物料自动排出, 可连续作业。

Material auto discharge, be able to continuous operation.

4. 新型网架结构, 筛网使用寿命长, 换网只需 3-5 分钟。

New type screen frame structure, long life, only 3-5 minutes to replace the screen.

5. 占用空间小, 移动方便, 出料口可以 360 度任意旋转。

small space occupation, convenient movement, discharge mouth can be rotating 360 degrees.

6. 全密闭结构, 粉尘不飞扬, 液体不泄露, 网目不堵塞、筛分可至 500 目, 过滤可达 5 微米。

full closed structure, no dust flying, no liquid leak, no mesh plug, screening effect can be reach 500 mesh, filtration can be reach 5 micron.

7. 可单层、多层筛网使用。建议使用三层。

Can be used for single-layer, multi-layers screening. Usually recommended to use at most four layers.

8. 针对不同行业的特殊需求，三次元振动筛分机还进行了独特设计，例如加缘式、闸门式、强力型、密封型等不同类型。（加图）

In view of the special needs of different industries, the three dimensional vibrating screen have many unique design types, such as edge type, gate type, strong type, sealed type and so on different types.

适用行业：

application industry:

化工行业：树脂、涂料、工业药品、化妆品等

Chemical industry: resin, paint, medicine, cosmetics etc.

食品行业：糖粉、淀粉、食盐、米粉、奶粉、豆浆、蛋粉、酱油、果汁等

food industry: sugar powder, starch, salt, rice flour, milk powder, soybean milk, egg powder, soy sauce, juice, etc.

金属冶金矿业：铝粉、铅粉、铜粉、矿石、合金粉、焊条粉末、二氧化锰、电解铜粉、电磁性材料、研磨粉、耐火材料、高岭土、碳氧化铝、石英砂等

Metal metallurgical mining industry: aluminum powder, lead powder, copper powder, ore, alloy powder, electrode powder, manganese dioxide, electrolytic copper powder, electric magnetic material, polishing powder, refractory material, kaolin, alumina carbon, quartz sand, etc.

公害处理：废油、废水、助剂、活性炭等

Pollution treatment: waste oil, waste water, additives, activated carbon, etc.

技术参数

型号 Model	有效筛分直径 Effective screening diameter (mm)	有效筛分面积 Effective screening area (m ²)	筛网规格 Screen mesh size (mesh)	层数(S) layer	振动电机 Vibration motor (kw)
DY-400	340	0.0907	2-500 目	1-3	0.18
DY-600	540	0.2289			0.38
DY-800	730	0.4183			0.55
DY-1000	900	0.6359			1.1
DY-1200	1100	0.9499			1.75
DY-1500	1400	1.5386			2.2
DY-1800	1700	2.2687			3
DY-2000	1886	2.7922			3

外形尺寸：

Overall dimensions:

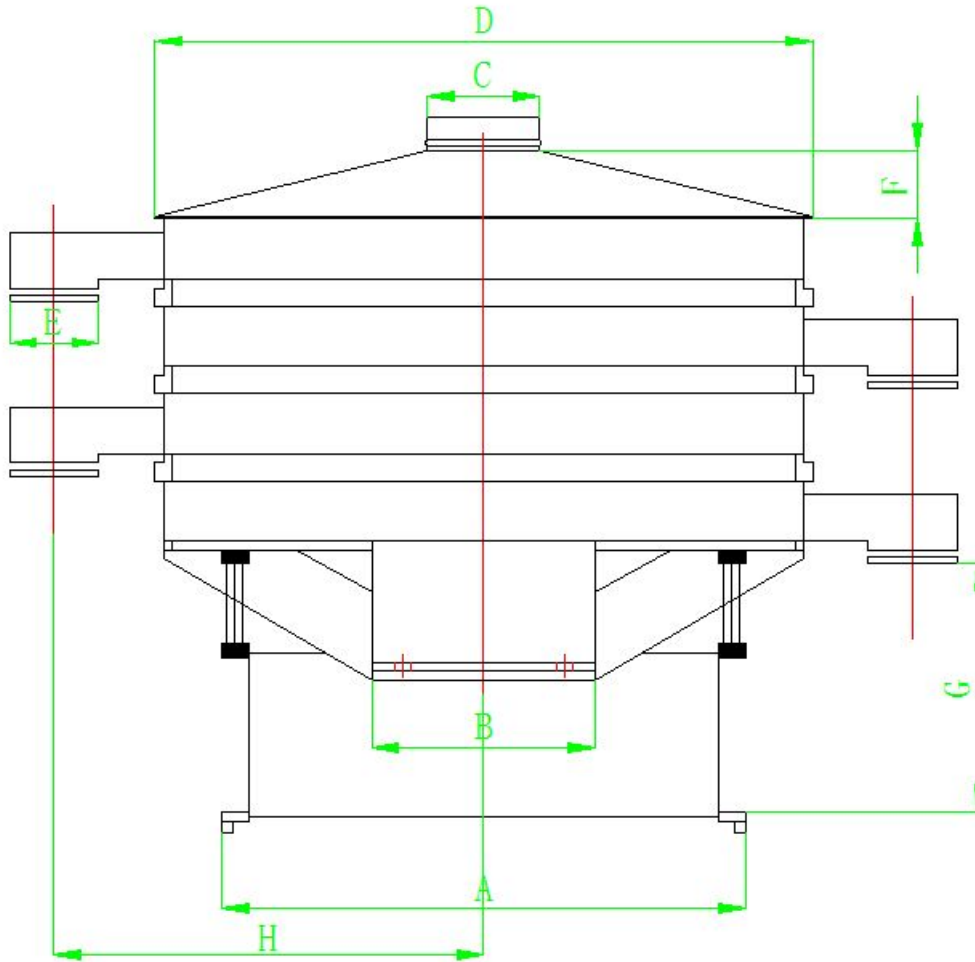

Model	A	B	C	D	E	F	G	H	Single layer	Double layers	Three layers
DY-400	330	305	240	400	80	70	390	320	635	770	870
DY-600	530	430		600	100		419	430	780	897	1013
DY-800	680	580		800	125	90	435	540	850	1003	1152
DY-1000	800	700		970	150	100	445	643	866	1015	1165
DY-1200	985	855	400	1170	180	120	555	750	1035	1204	1373
DY-1500	1190	1050		1470	200		556	930	1072	1249	1425
DY-1800	1540	1440		1770		170	680	1025	1225	1394	1562
DY-2000	1800	1720		1960	1260			1250	1420	1586	